

POWERFLEX®

PART NUMBER

PFF3-702G

DESCRIPTION

FRONT LOWER RADIUS ARM TO CHASSIS BUSH

INSTALLATION GUIDE

Contents (parts per pack):

2 x Polyurethane Bushes	2 x Stainless Steel Sleeves
2 x Mild Steel Outer Shell	4 x Mild Steel Washers
1 x Adjustment Spanner	1 x PFTE Grease

Please read the complete fitting instructions and check package components before fitment. These fitting instructions are to be used as a guide and in conjunction with workshop manual.

It is recommended that:

- all work to be carried out by a licensed technician;
- all safety precautions adhered to;
- wheel alignment to be checked and adjusted as required after any suspension work.
- All fasteners must be tensioned to manufacturer's torque settings.

Fitting Instructions:

1. Remove the original bush from the rear trailing arm including the outer shell, and clean away any dirt or corrosion. File away any sharp edges to prevent damaging the new bush.
2. In the orientation shown in Figure 2, press the outer shell into the bore of the arm, ensuring the lip of the shell sits flush to the arm.
3. Press the Powerflex bush into the bore of the outer shell. To ease this, apply some washing up liquid to the lip of the bush. Ensure that the bush sits firmly in the arm, as shown in Figure 2.
4. Apply some Powerflex Grease to either side of the bush, then fit sleeve and washer together and press into the bush as shown in Figure 2. Once pressed in fit second washer on other end of the bush as shown in Figure 2.
6. Refit arm to vehicle and tension all fasteners to manufacturers recommended torque settings.



Figure 1

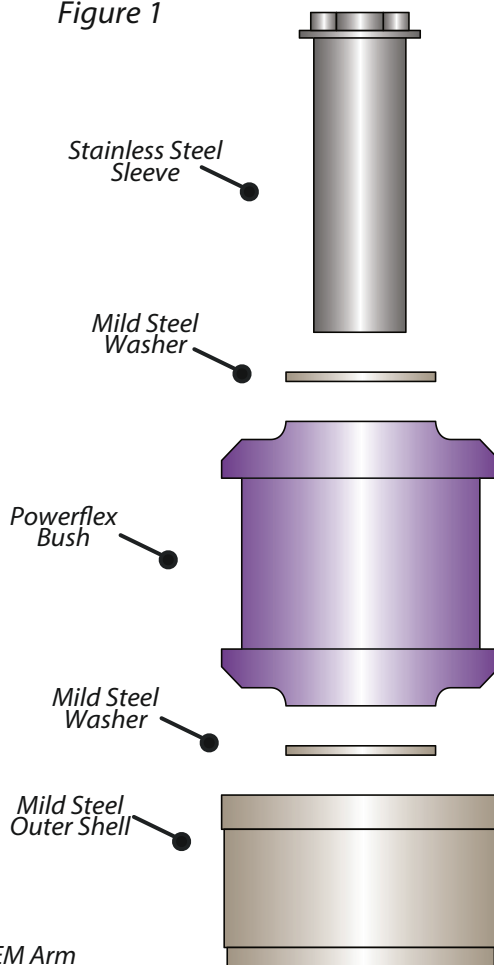

Figure 2

